

Three Way Hand Truck Assembly Instructions

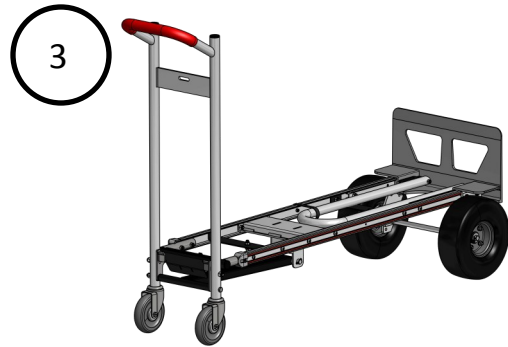

Tools Required:

- (2) 1/2" wrench/socket
- (1) 7/16" wrench/socket
- (1) #2 Phillips screwdriver
- (1) Needle nose pliers

*Nose pate, and wheels will vary based on the options selected at the time of purchase.

www.bpmfg.com

8051 East Boon Road | Cadillac, MI 49601

(800) 334-7141

b&p Manufacturing
Engineered Delivery Products

Three Way Hand Truck Components

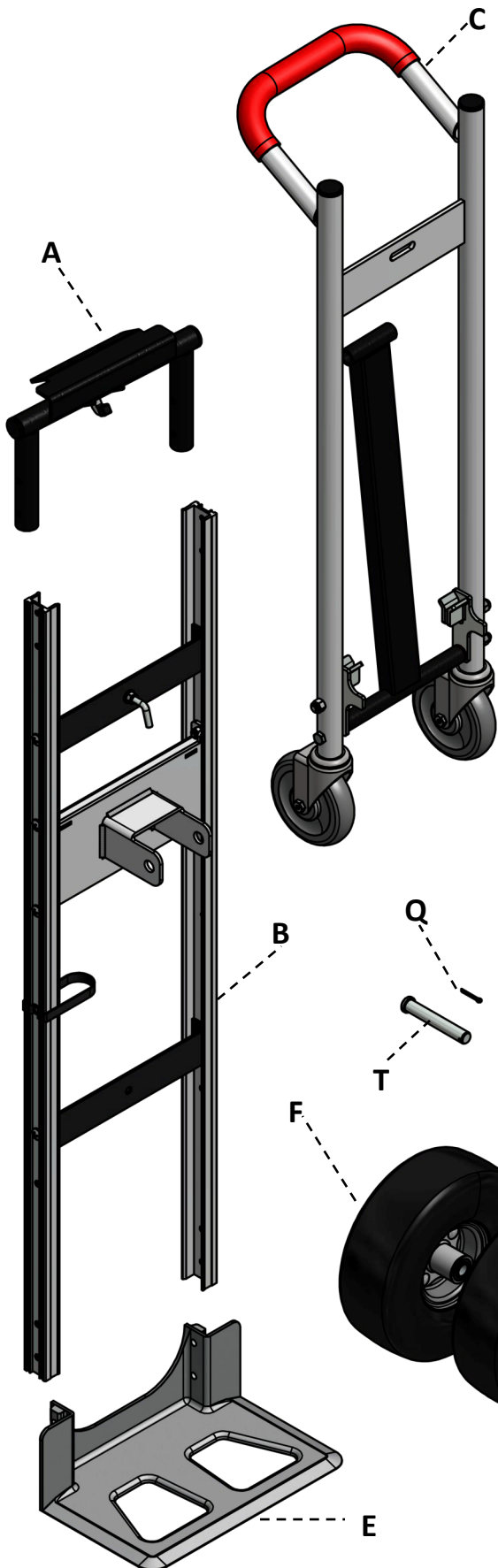

Item	Description	Qty.	Part No.
A	Handle	1	2002-B60
B	Frame	1	2002-B60
C	4th Wheel	1	2002-B60
D	Folding Nose	1	Various
E	Nose Plate	1	Various
F	Wheel	2	Various
G	Axle, Long—10" Wheels	1	2001-201
H	Side Channel Reinforcement	2	2002-733
I	Axle Bracket, LH	1	2001-701
J	Axle Bracket, RH	1	2001-702
K	End Cap	2	8226-001
L	Hex Head Bolt, 5/16"-18 x 2-1/4"	4	8007-016
M	Lock Nut, 5/16"-18	2	8001-005
N	Pan Head Screw, 1/4"20 x 1-3/4"	4	8068-003
O	Lock Nut, 1/4"-20	4	8001-004
P	Pan Head Screw, 5/16"-18 x 1-1/4"	2	8068-005
Q	Cotter Pin	3	8008-001
R	Washer, 5/8"	4	8003-010
S	Thin Washer, 5/8"	4	8078-010
T	Clevis Pin	1	8211-010
U	Jam Nut, 5/16"-18	4	8055-005

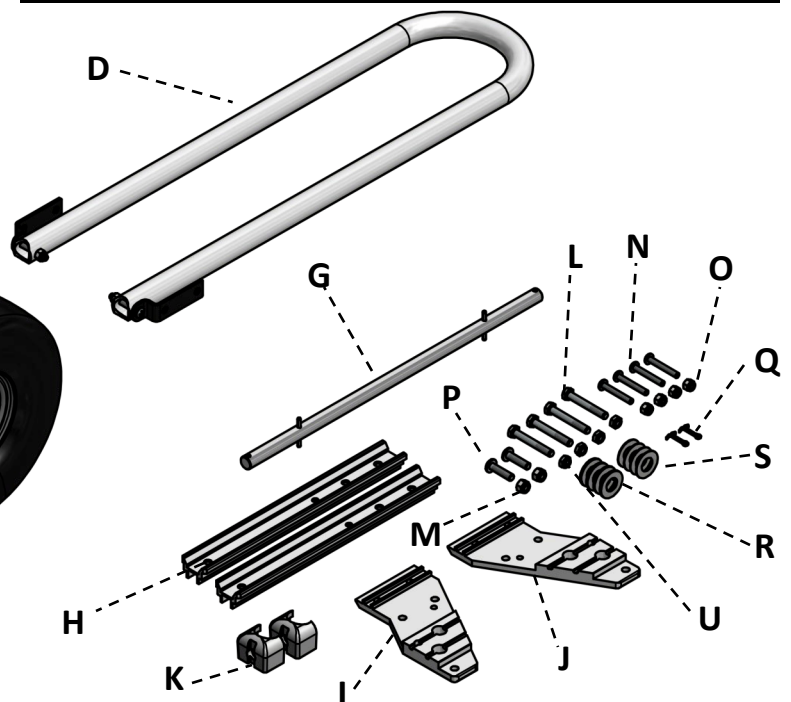

Three Way Hand Truck Assembly

1. To begin start with the frame (B) and attach a side channel reinforcement (H) to the inner channel of each frame leg, securing with a 5/16"-18 x 1-1/4" pan head screw (P) and nut (M) thru the top hole of the reinforcement. Do not tighten completely.
2. Slide handle (A) into the top of the hand truck frame. Cap ends of the frame with end caps (K) and secure with 1/4"-20 x 1-3/4" screws (N) and lock nuts (O).

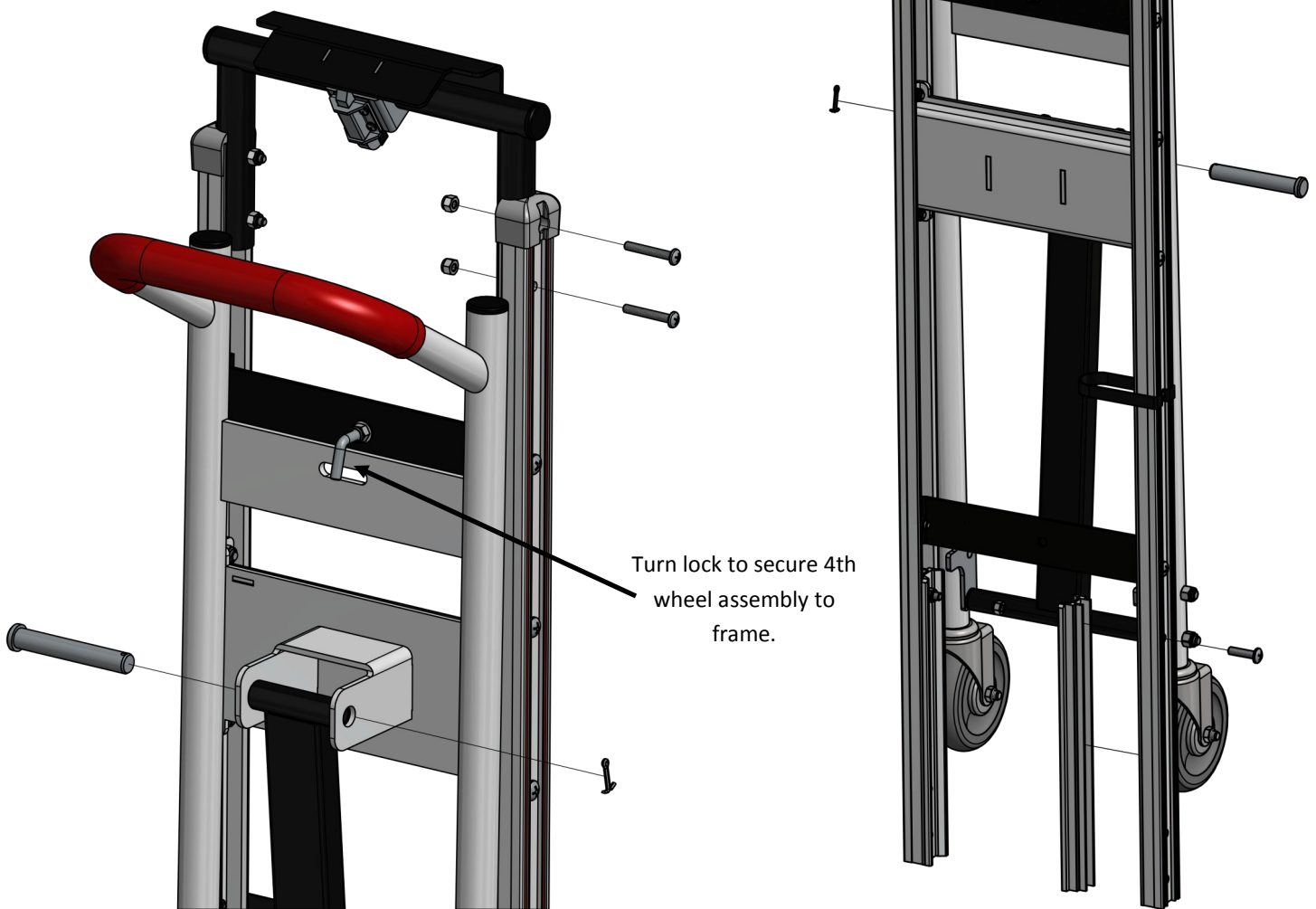

3. Next attach the 4th wheel to the frame, securing the shaft to the frame bracket with clevis pin (T) and cotter pin (Q). Turn the lock on the frame to secure the top of the 4th wheel assembly to the frame. When fully assembled turn this lock to release the 4th wheel for use.

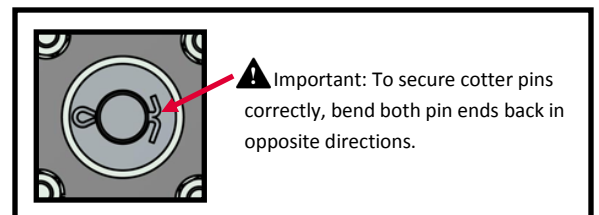

Three Way Hand Truck Assembly

- Slide the nose plate (E) on to the bottom of the frame. Then align the brackets on the folding nose (D) with the holes in the nose plate as shown.
- Place the left (I) and right (J) axle brackets onto the outside of frame and secure with 5/16" -18 hex bolts (L) and jam nuts (U), passing the bolts thru the folding nose brackets, nose plate, frame reinforcements, frame and axle brackets. Install one side at a time, placing the axle (G) between the brackets and aligning the spring pins with the slots in the brackets. Tighten all fasteners.

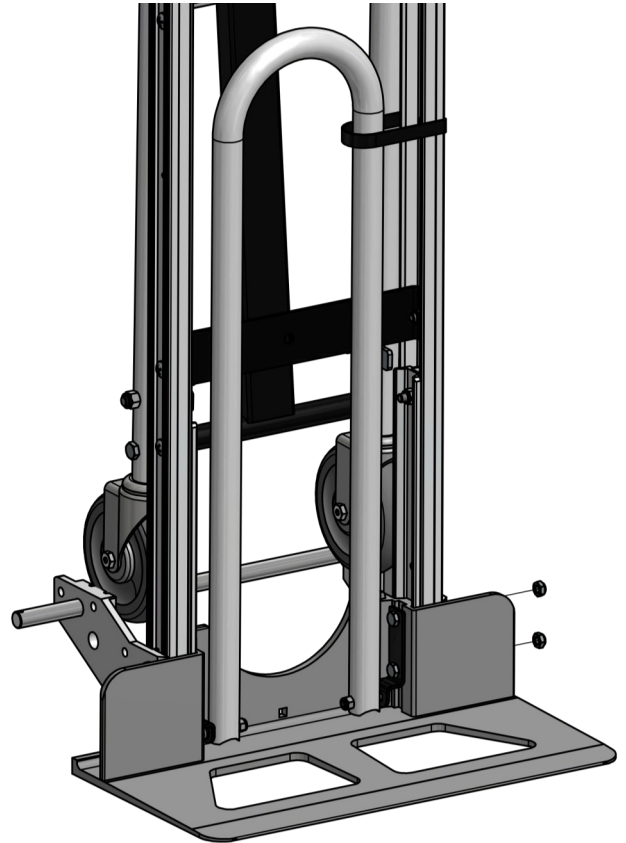

- Use the Velcro strap attached to the frame to secure the folding nose in the upright position when not in use.
- Install the wheel assemblies (F) on to the axle. Place two washers (R) onto the axle followed by the wheel. Place two thin washers (S) on the axle and secure to the axle with a cotter pin (Q). Repeat for opposite side.

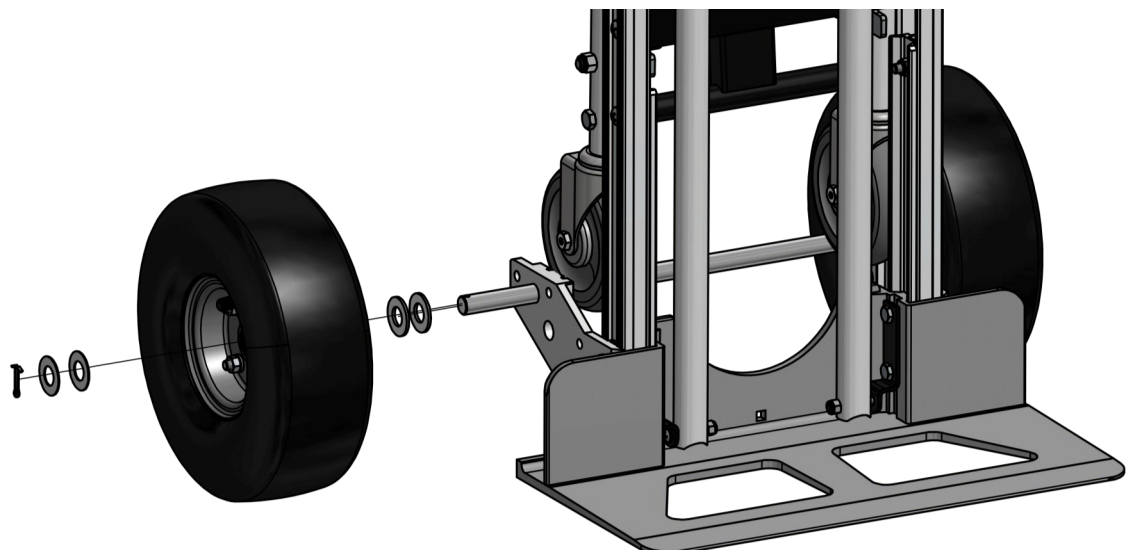

Three Way Hand Truck Positions

Angled Frame Position

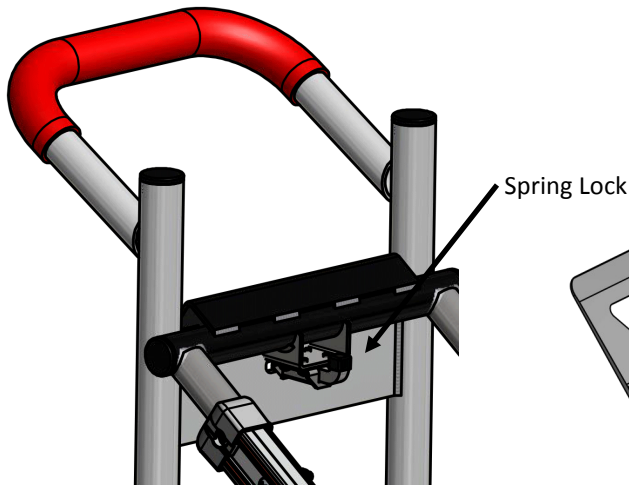

1. Unlock the 4th wheel from the frame, then pivot the assembly so the top of the frame handle contacts the cross member just below the red handle, causing the spring lock to engage into the hole.
2. To release, pull the spring lock to disengage and pivot the assembly.

Horizontal Frame Position

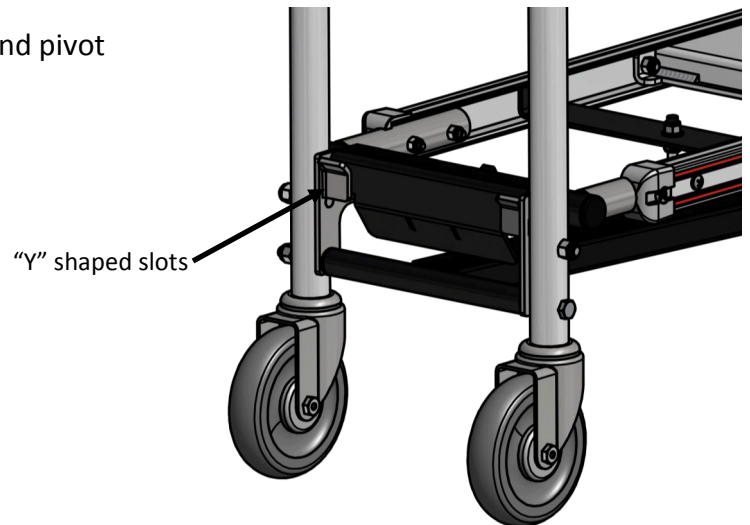

1. Unlock the 4th wheel from the frame, then pivot the assembly so the frame and 4th wheel assembly are perpendicular to each other. Secure by sliding the tab of the handle into the "Y" shaped slots on the 4th wheel assembly.
2. To release, lift and pivot the assembly back into the upright position.